

# PRODUCT: CELLULAR/HONEYCOMB SHADES

## SPECIFICATIONS

### 1. DESCRIPTION

- A. **Crystal Pleat 3/8" double cell shades.**
- B. **Fire-retardant.**

### 2. HEADRAIL

- A. 0.665" high and 1.540" deep.
- B. **Extruded aluminum headrail.**
- C. Wall thickness of 0.045" and painted to coordinate with fabric color.

### 3. CORD LOCKS

- A. **Snap in design.**
- B. Comprised of injection molded thermoplastic incorporating a metal, free floating, serrated cord locking roller.

### 4. LIFT CORD

- A. 1.2mm polyester concealed for a clean appearance.
- B. Snap tassel and joiner ball connect to a single Danskord for raising and lowering the shade.
- C. Cord, tassel, and joiner ball are all color coordinated with fabrics.

### 5. SHADE FABRIC

- A. 3/8" double insulated cell construction.
- B. **Flame retardant fabrics pass NFPA-701 Federal standards and California requirements for FR performance.**
- C. Fabric shall be 100% point bond polyester offering semi opaque privacy with and R-value of 2.90.

### 6. INSTALLATION BRACKETS

- A. Low profile.
- B. **Hidden snap in design.**
- C. Made from 0.025" zinc plated spring steel.

### 7. BOTTOMRAIL

- A. Shall be 0.36" high by 1.54" deep extruded aluminum.
- B. Wall thickness of 0.045".
- C. Painted to coordinate with fabric color.

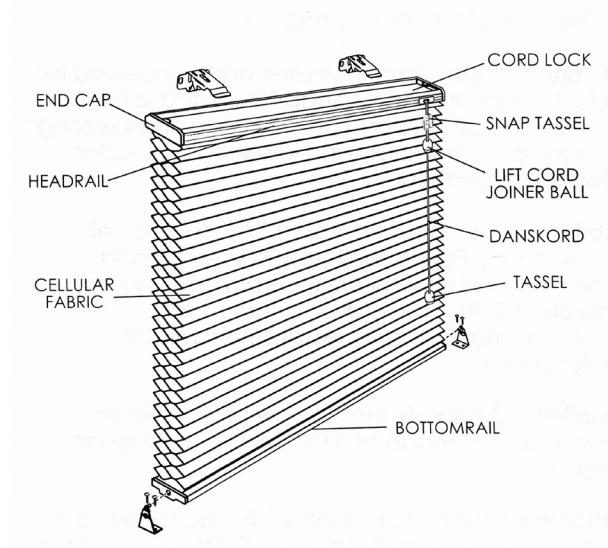

### 8. OPTIONS

- A. Continuous cord loop lift system.
- B. **Bottom up/top down.**
- C. Multiple shades on one headrail.

### 9. MAINTENANCE AND CLEANING

- A. Clean fabric by regular dusting; or vacuum with a soft brush attachment.
- B. Do not use cleaning methods involving heat, bleach, abrasives, or solvents.
- C. Use of these methods will void the warranty.

### 10. OPTIONS

- A. No holes slats.
- B. Cloth tapes to cover cord ladders at 1 1/2" or 1" wide.
- C. Wand tilter.
- D. Extension brackets.
- E. Hold down brackets.
- F. Cut outs.

### 11. LIMITED LIFETIME WARRANTY

- A. **Warrants the headrail against original defects in materials or workmanship for the life of the shade and the fabric for three years.**
- B. This warranty does not cover damage due to accident, misuse, abuse, improper installation, alterations, or improper cleaning.